

Techman Plugin Quick Start Manual

Model Name: ARH350A

Rev. 1.00



Shinano Kenshi Co., Ltd.

1. Installation



- If a plug-in from another company is installed, the robotic gripper may malfunction. Please uninstall unnecessary plugins first.

1.1. Installation Instructions

1. Connect the USB device with the downloaded component to the robot controller.
2. Click Import/Export from the system menu.

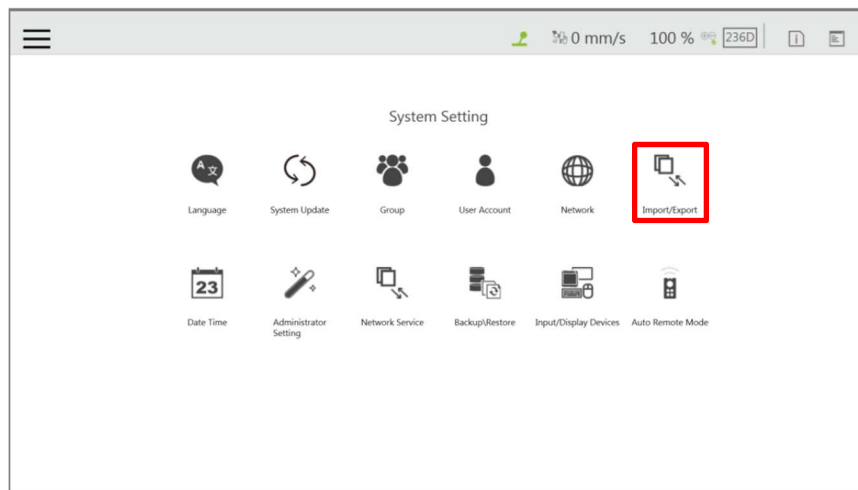

3. Select the Import button.

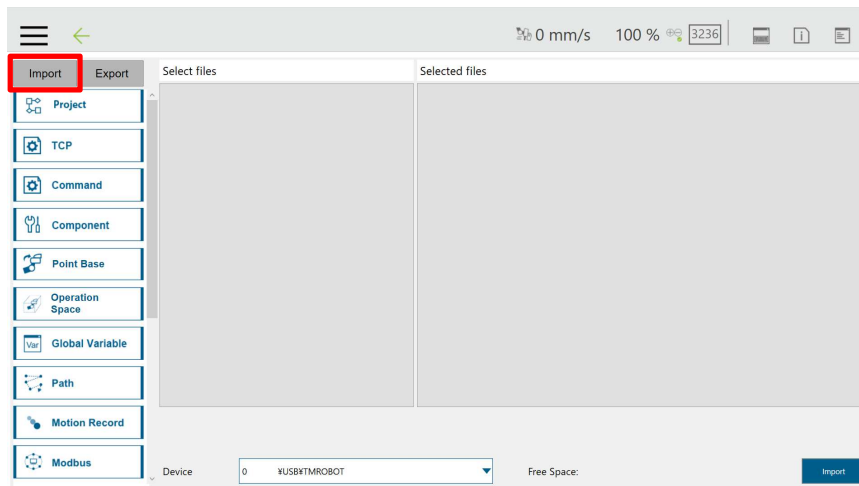

- Select the robot and click the OK button.

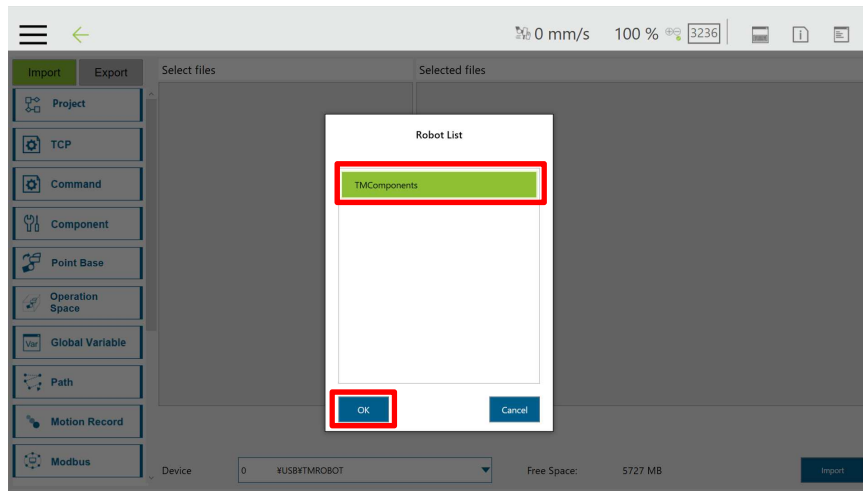

- Select a component from the import list.

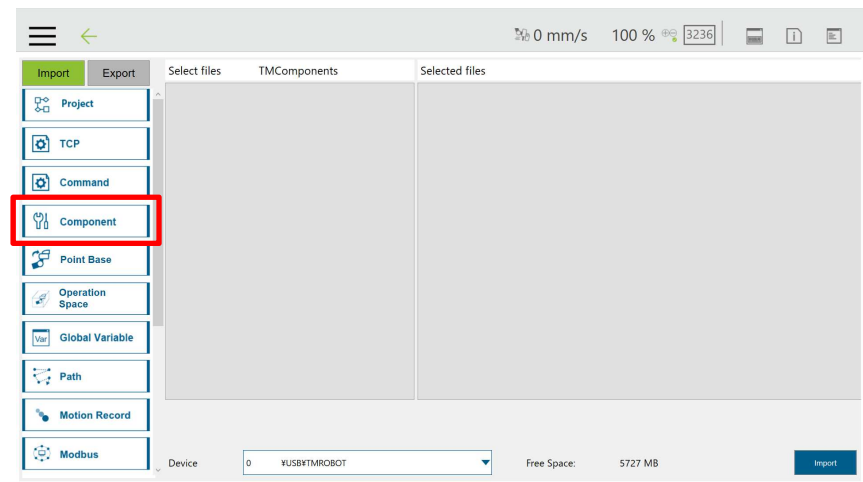

- The component appears in the file list.

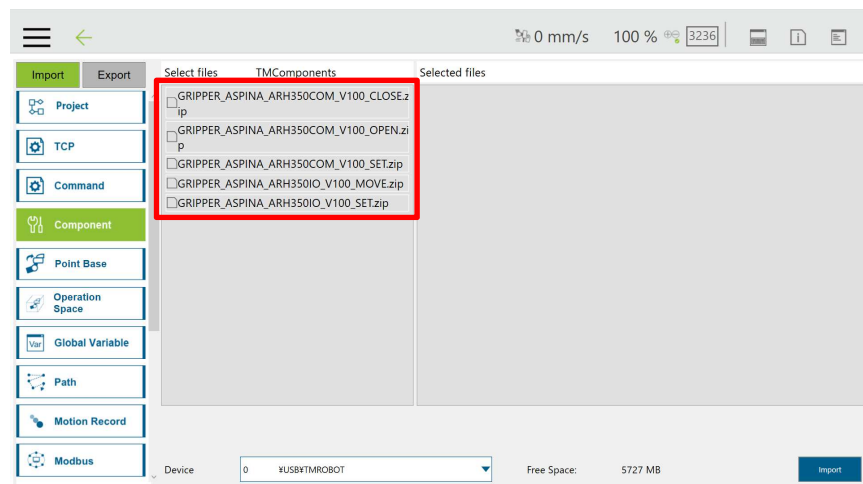

7. Select all components in the file list, confirm that they have been moved to "Selected Files", and press the Import button.

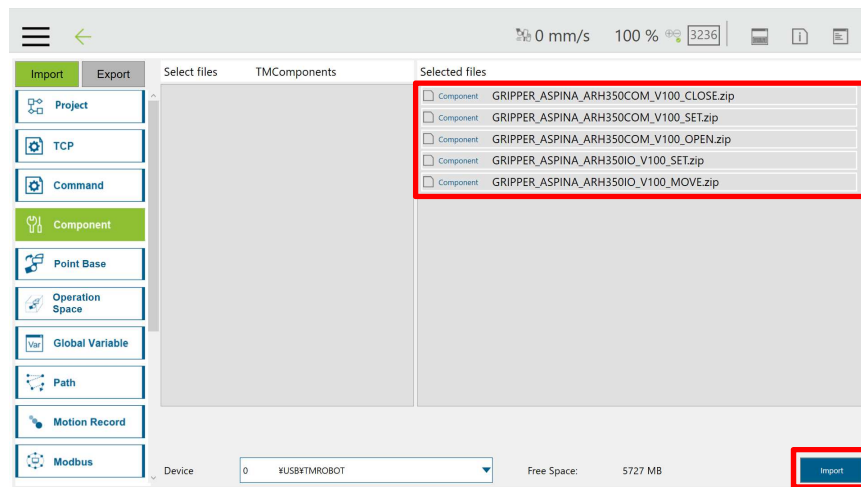

8. Confirm that the process is successful and press the OK button.

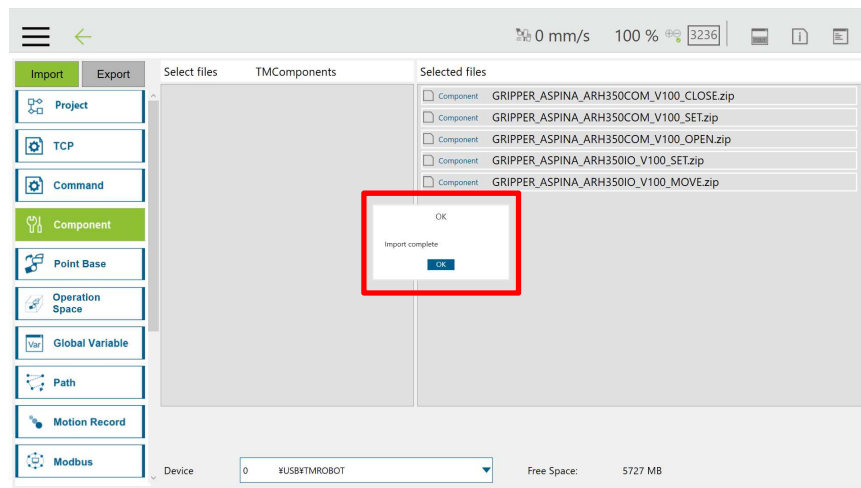

9. Select Settings from the System menu and select a component.

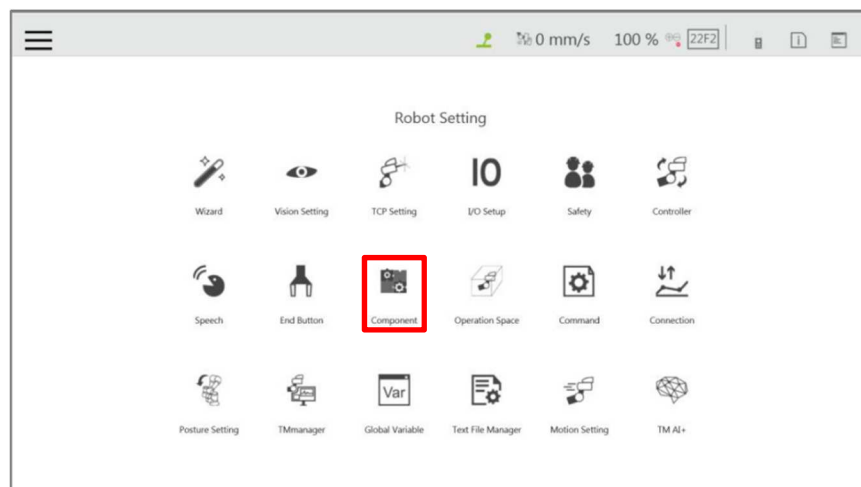

10. Click the radio button for the imported component to enable it and select Save.

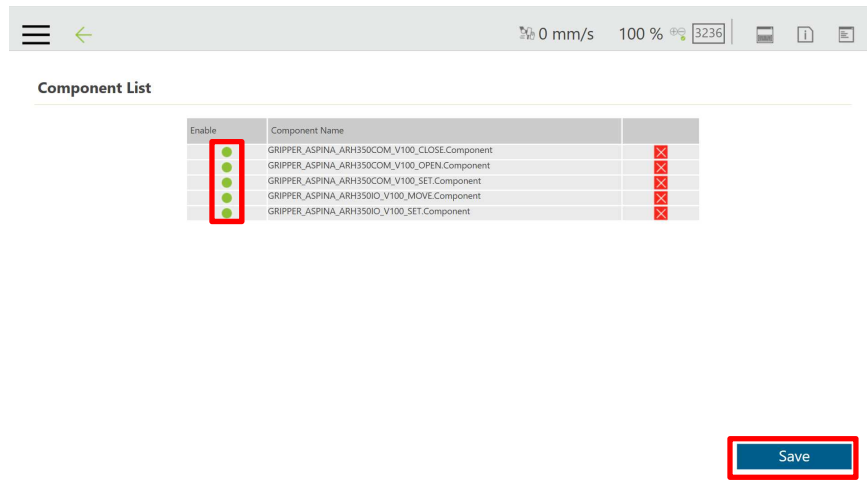

11. Launch a new project and confirm that the component has been added to the node list.

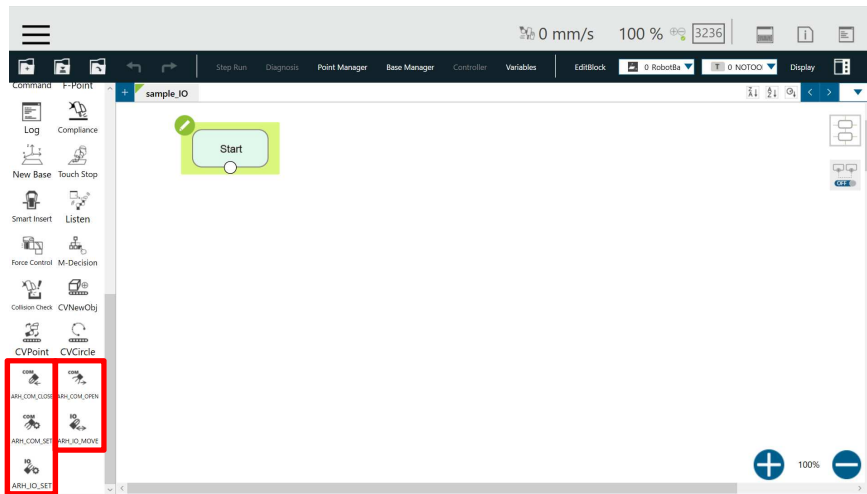

1.2. Uninstallation Instructions

1. Select Settings in the menu and select Components.

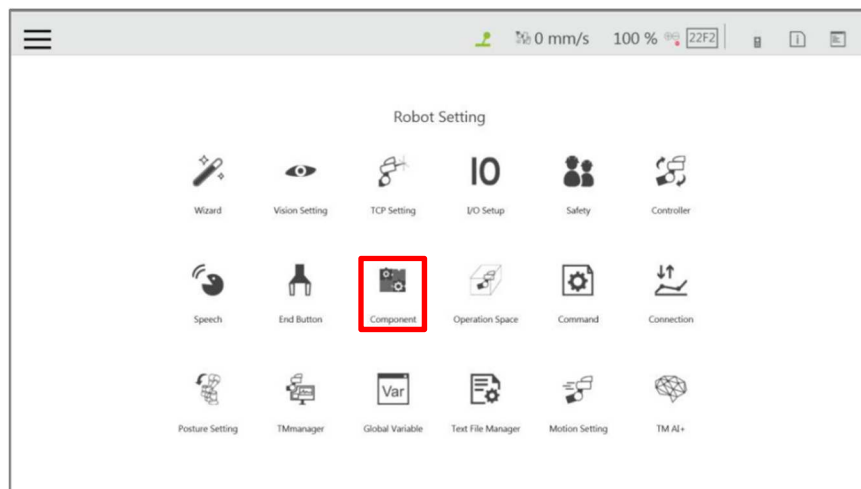

- Select the x mark to the right of the component that the user wants to uninstall and select OK on the warning screen.

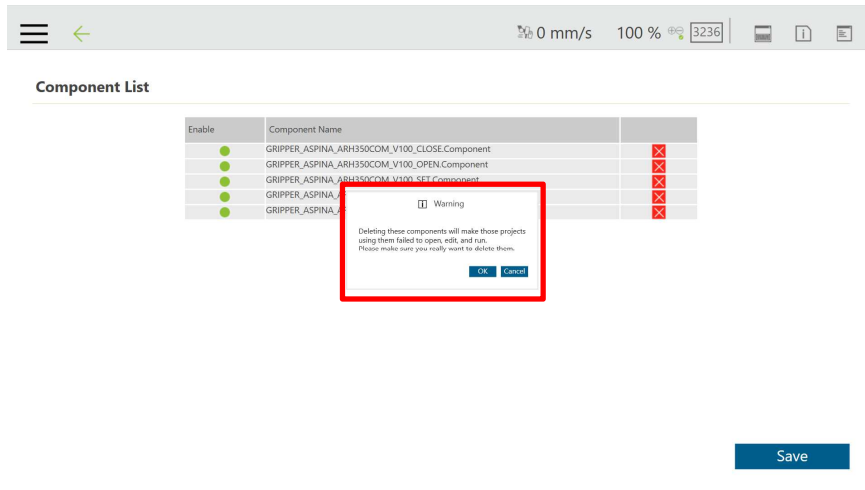
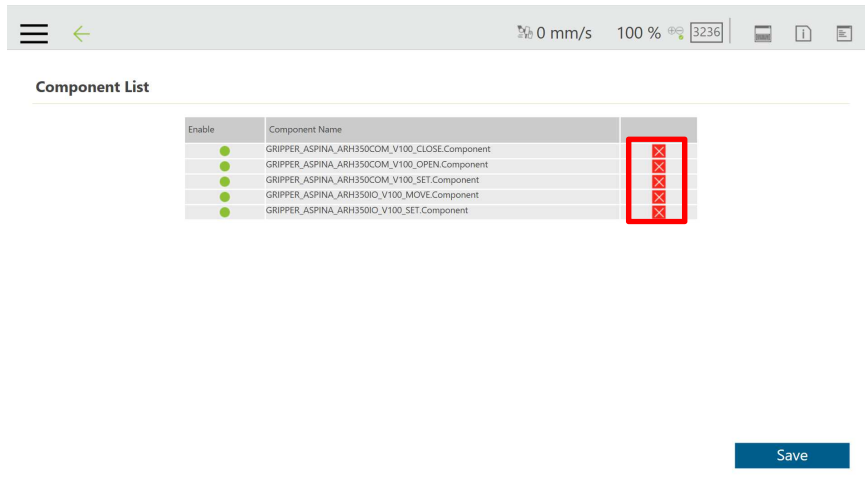

- Confirm that the component is removed and select Save.

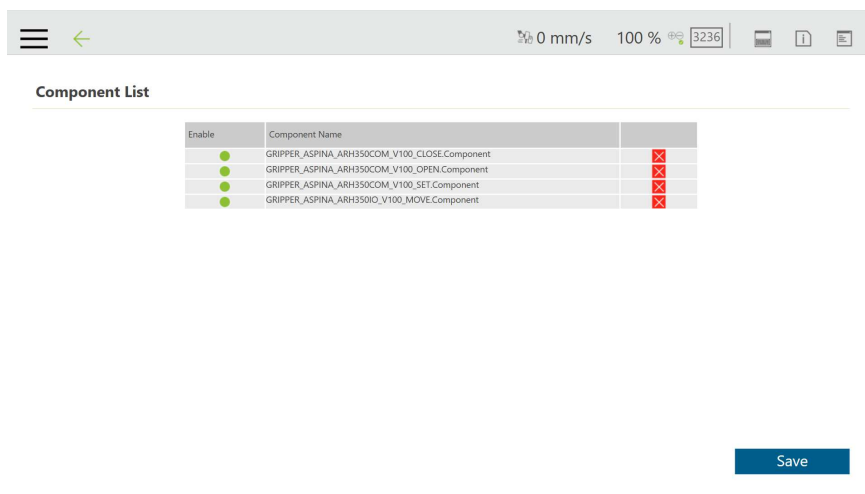

4. Launch a new project and check the node list to see that the component has been removed.

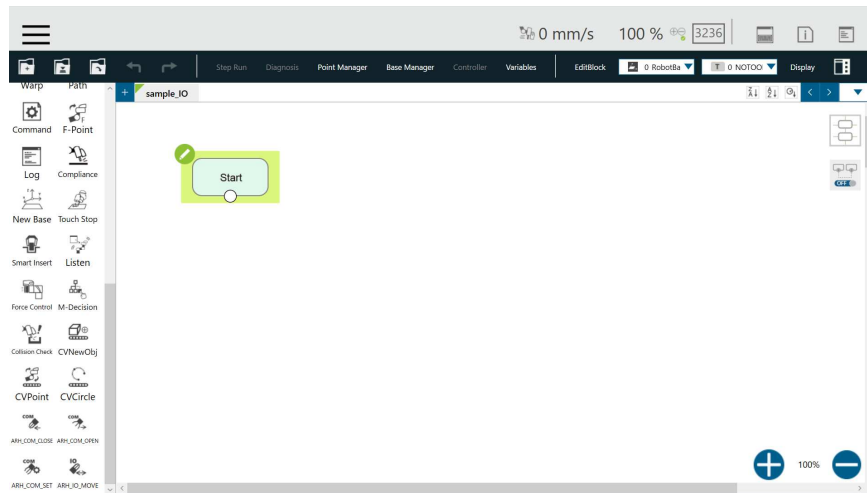

2. How to install on the robot



·When installing with the robot, make sure that the power of the robot is off.

2.1. Installation of robotic gripper

1. Attach the dedicated attachment-A to the robotic gripper body.

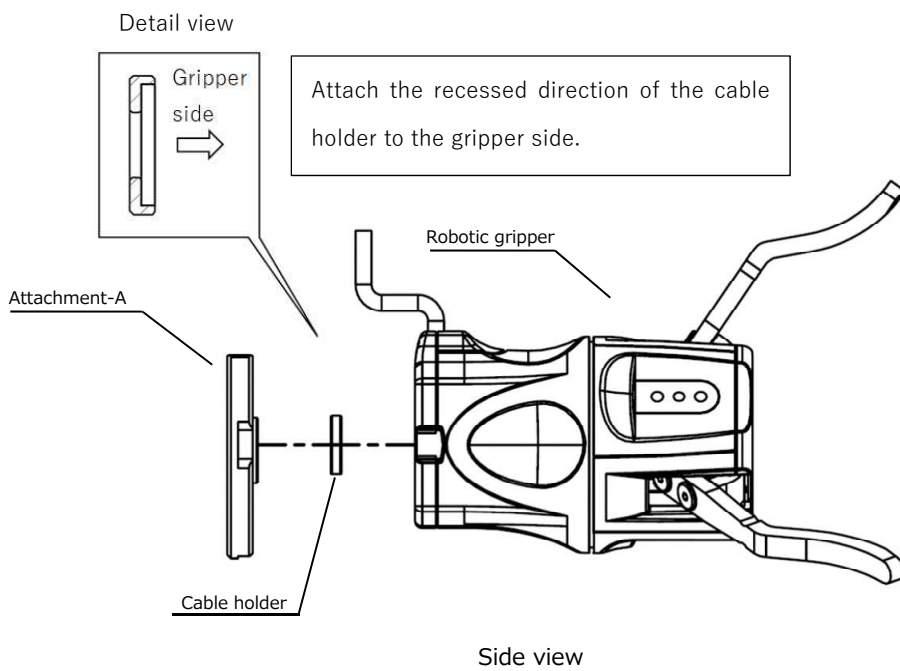
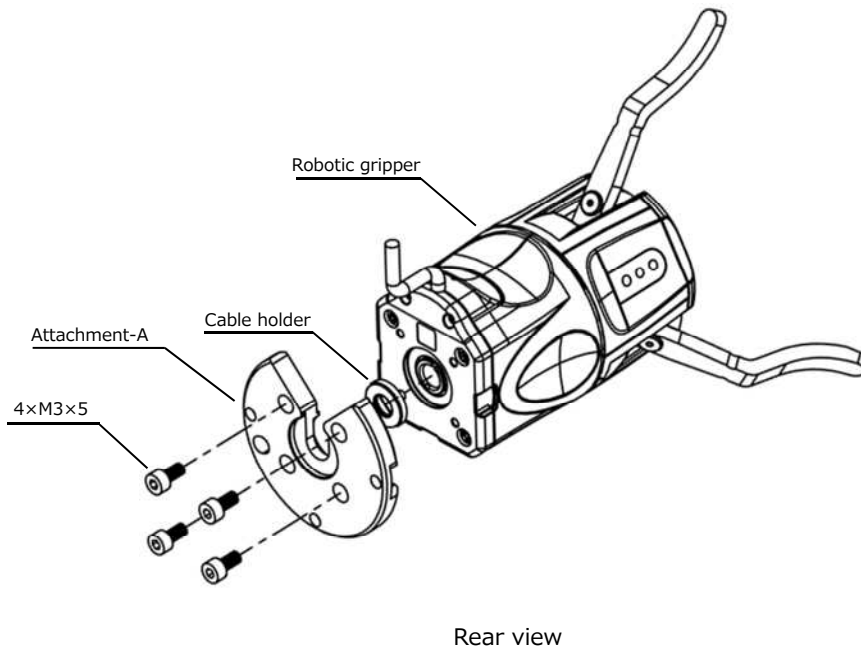

- Attach the dedicated Attachment-B to the robot.

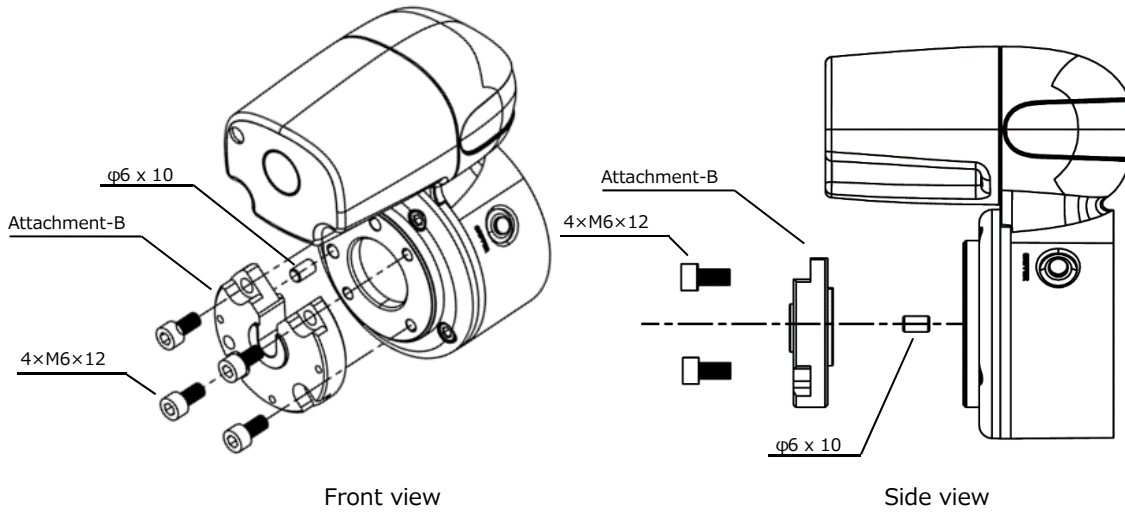

- Attach 1 and 2.

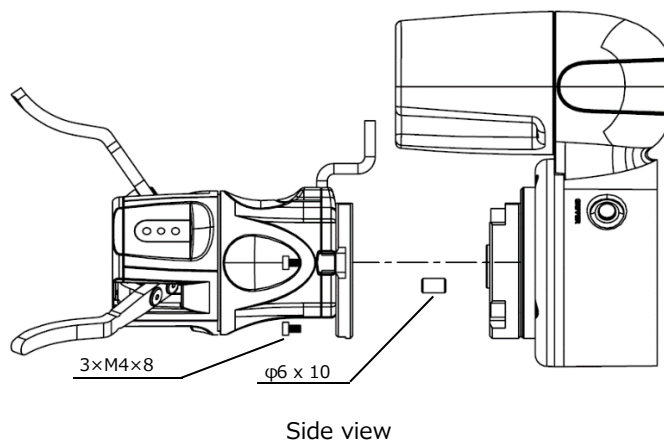
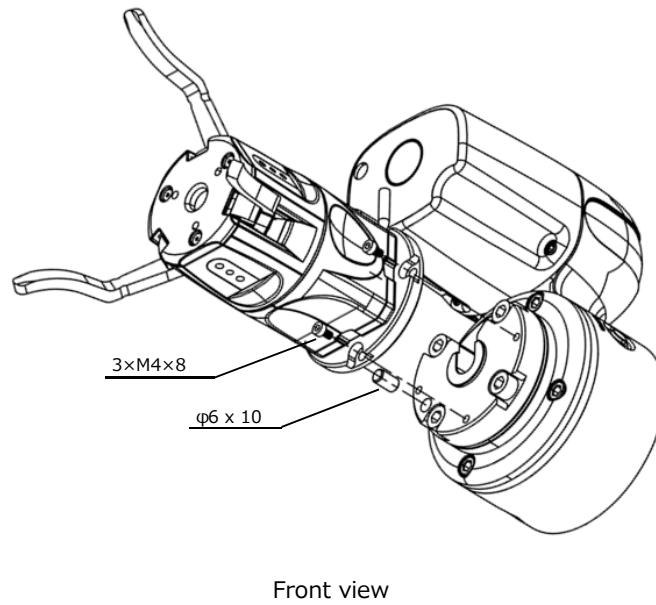

4. Installation is complete.

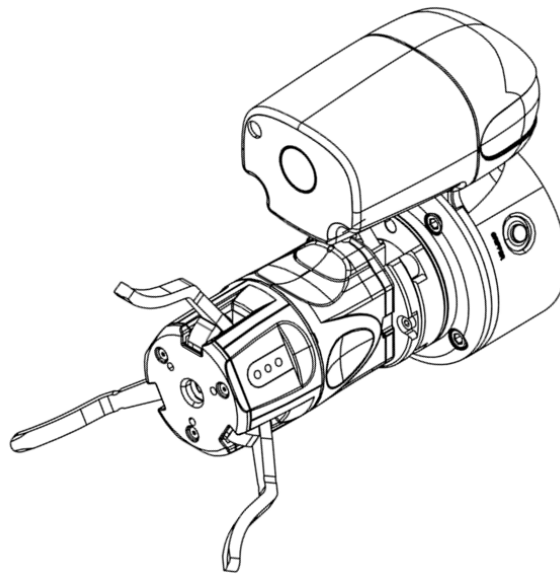

※By changing the position of the positioning pin and attachment-B direction in step 2, The robotic gripper can set the position of 4 patterns. (Every 90°)

Positioning pin position(red circle)	The position of 4 patterns	

2.2. Wiring method



·When wiring with the robot, keep the power of the robot turned off.

2.2.1. I/O control connection

1. Connect the robotic gripper body cable to the conversion cable.
2. Connect the round connector of the conversion cable to the digital I/O of the robot end module.
3. The connection is now complete. ※ Please refer to chapter 4.1 for more information on the operation.
(If there is a surplus of cables, consider making the wiring run around the robotic gripper.)

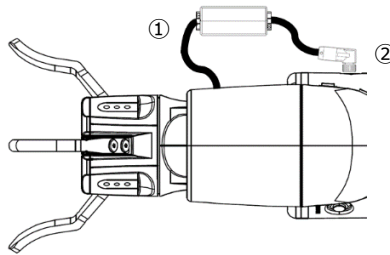

2.2.2. Communication control connection

1. Connect the robotic gripper body cable to the standard cable.

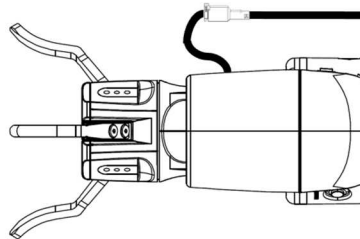

2. Fix the standard cable to the robot.
3. Turn on all the switches on the back of the RS485 to RS232C converter. (Set 2-wired RS-485, Terminator Enable)

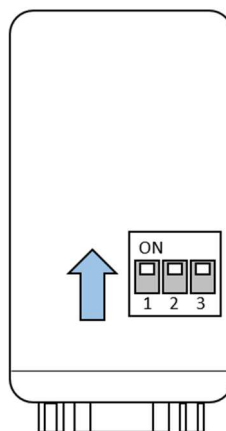

- Connect the standard cable to the RS485 to RS232C converter. Use GND as the power supply for the robot controller. (Bypass by the robot controller or by the wire itself)

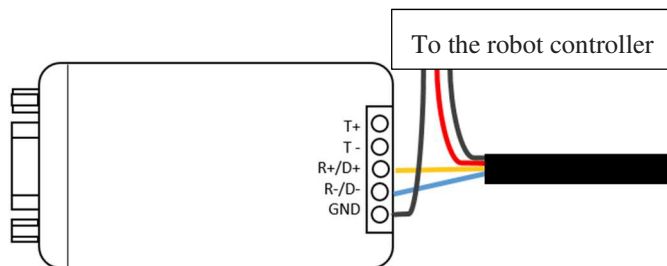

- Connect the 24 V GND line to the robot controller.

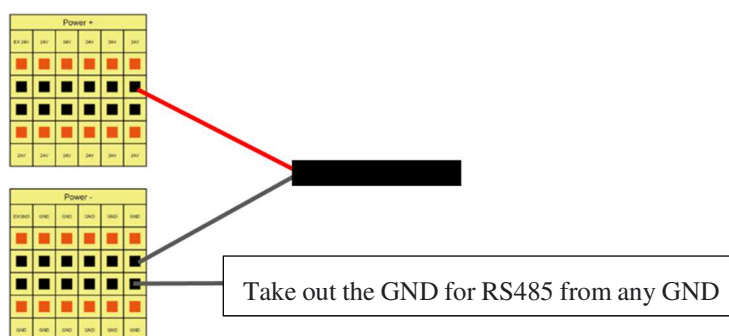

- Connect the RS 485 to RS 232 C converter and RS 232 C cable (0.5 m). Connect the other RS 232 C cable to any com port on the robot controller.

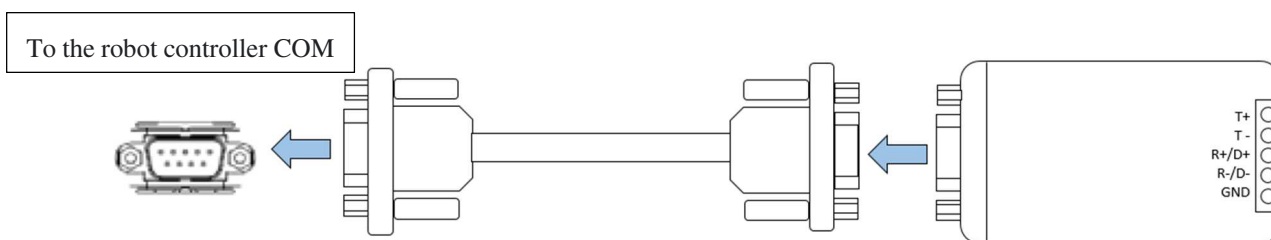

- Insert the DC plug supplied with the RS485 to RS232C converter into the RS485 to RS232C converter and connect USB type A to the USB port of the robot controller.

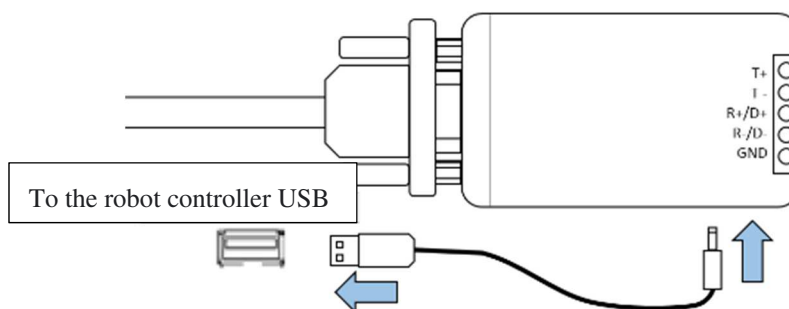

8. The connection is complete. ※ Please refer to chapter 4.2 for more information on the operation.



- If the the robotic gripper RS 485 +/- cable is inserted incorrectly, communication will fail.
- Incorrect connection between 24 V and GND may cause fatal defects in the robotic gripper.
- The converter may not operate properly unless power is supplied through the DC plug.

3. Robot Initialization

3.1. TCP Settings

1. Select Settings from the menu, and then select TCP Settings.
2. Select manual parameter entry for TCP.
3. Set Z, Mass as follows:
 - Z: 173.5 (mm)
 - Mass: 0.8 (kg)

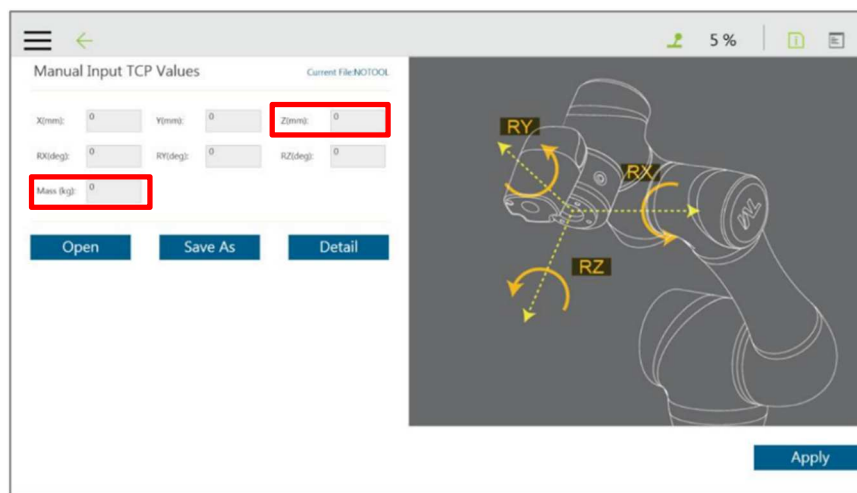

3.2. Setting the Gripper Button

- Case of I/O control
 1. Select Settings from the System menu, and then select the Gripper button.
 2. Select "General Gripper Output" and set it as follows.
 - Grip: End Module out 0 = High
 - Release: End Module out 0 = Low
 3. Start a new project and press the gripper button to see how it works.
- Case of communication control
 1. Select Settings from the System menu, and then select the Gripper button.
 2. Select "Use Customized Components" and set it as follows.
 - Grip: "GRIPPER _ ASPINA _ ARH 350 COM _ V 100 _ CLOSE"
 - Release: "GRIPPER _ ASPINA _ ARH 350 COM _ V 100 _ OPEN"
 3. Start a new project and press the gripper button to see how it works.

4. Robot program

4.1. I/O control

The operation pattern set on the robotic gripper is controlled by digital I/O to operate the robotic gripper.

4.1.1. IO SET Components

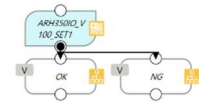
Component	Component Content	Node
 ARH_IO_SET	To set DI0 and DI1 of a robot when performing I/O control.	

The various parameters are as follows:

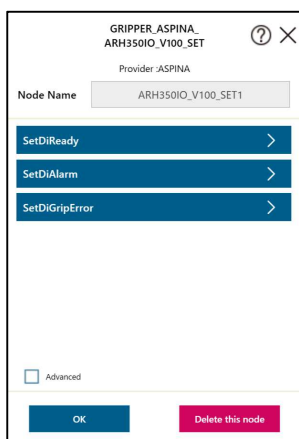

The user should set the function (Ready / Alarm / GripError) to the end modules DI0 and DI1. Assign values (-1, 0, 1) to the parameters, respectively. Each value means the following contents.

- 1: Unassigned
- 0 : Assign function to the end module DI0
- 1 : Assign function to the end module DI1

Parameter	Variable	Parameter Name	Setting range	Initial value	Contents
Basic					
SetDiReady	numDiReady	Set Ready	-1 to 1	-1	Set Ready to the end module DI *
SetDiAlarm	numDiAlarm	Set Alarm	-1 to 1	-1	Set Alarm to the end module DI *
SetDiGripError	numDiGripError	Set GripError	-1 to 1	-1	Set GripError to the end module DI *



- Check that the setting of DIO 3 and 4 of the robotic gripper is the output. Do not assign inputs.
- The factory defaults for robotic grippers are DIO3 = GripError and DIO4 = Alarm. Therefore, DIO of the robot turns ON / OFF according to the range of GripError. The output of robot DI1 is fixed because it is not an alarm.
- If the DI setting of the robot is different from the output setting of the robotic gripper, unexpected behavior may occur.

4.1.2. IO MOVE Component

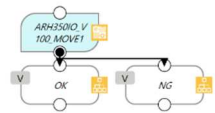
Component	Component Content	Node
 ARH_IO_MOVE	To set the robotic gripper operation parameters when performing I/O control.	

The various parameters are as follows:

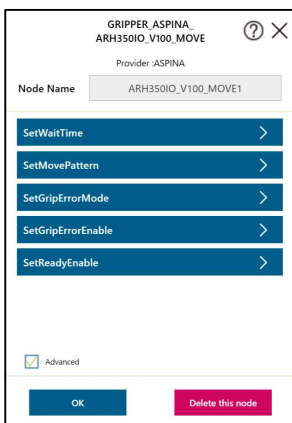

Parameter	Variable	Parameter Name	Setting range	Initial value	Contents
Basic					
SetWaitTime	msecWaitTime	waiting time	0 ~ 10,000 msec	1000	Sets the standby time for the open/close operation.
SetMovePattern	numMovePattern	move pattern	1 ~ 4	1	Sets the move pattern of the robotic gripper. Setting 1 ~ 4 is equal to 0 ~ 3 in the operation number.
SetGripErrorEnable	GripErrorEnable	Grip error permission	true/false	false	The user can enable or disable Grip errors.
SetReadyEnable	ReadyEnable	Ready permission	true/false	false	The user can enable or disable the Ready. When Ready is disabled, the time set by SetWaitTime works.

Parameter	Variable	Parameter Name	Setting range	Initial value	Contents
Details					
SetGripErrorMode	GripErrorMode	Grip error mode change	true/false	false	It can be set to Pause/Stop processing after a gripper error. Pause (true): The flow will pause after detecting a grip error. Stop (false) : The flow will stop after detecting a grip error.



- The ReadyEnable value is ignored if Ready is not assigned.
- The GripErrorEnable value is ignored if GripError is not assigned.

4.1.3. IO Control Sample Program

- The initial settings of the robotic gripper are as follows. (factory default)

Terminal Name	I/O settings	Assignment
DI1	Input (Fixed)	SEL [0]
DI2	Input (Fixed)	Alarm Reset
DIO 3	Outputs	GripError
DIO 4	Outputs	Alarm

For details, please refer to the "ARH350A Operation manual 4.6. Parameter settings".

The move pattern 1 ~ 4 is equal to the operation number 0 ~ 3 in the "ARH 350A Instruction Manual 7.5.5. Individual operation". The default values are as follows.

Move pattern	Operation number	Target position [%]	Operation time [%]	Positioning torque limit [%]
1	0	0	100	80
2	1	100	100	80
3	2	0	100	80
4	3	100	100	80

Please use the dedicated app (RobotHandSetup) to change the parameters and pin functions of the robotic gripper. For details, please refer to the "RobotHandSetup_QuickStartManual".

- Please create a new project. Click pencil mark on the Start node.



- Disable [Reset AO DO while Project Initializing].

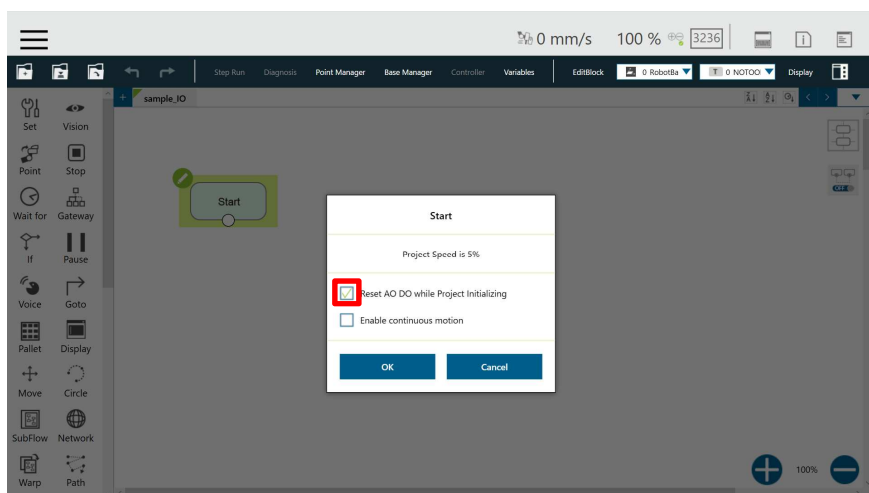

- Make sure it is unchecked and click OK.

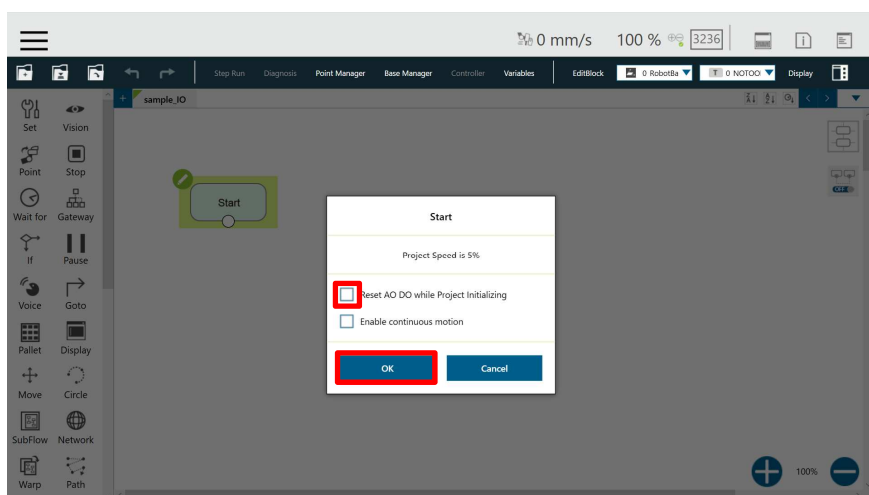



- If uncheck process is not done, there is a possibility that the robotic gripper will make unintended movements.

5. Drag  and drop the into the flow.

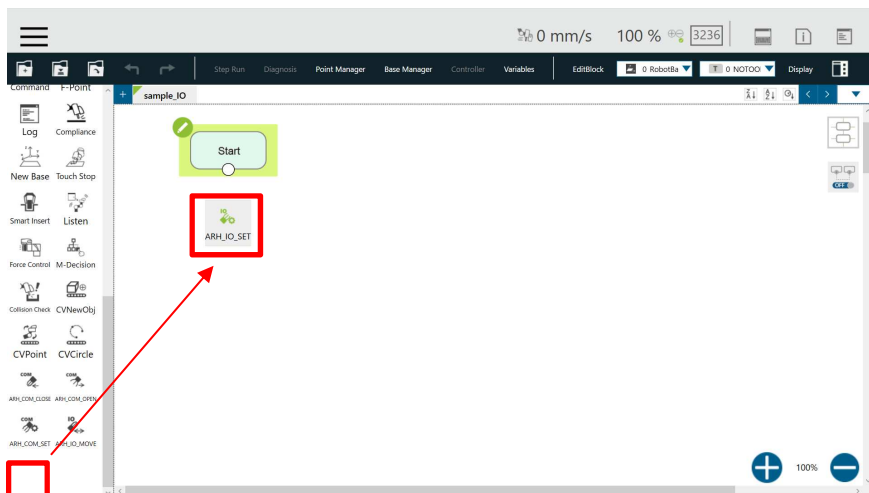

6. The node is added to the program. Select the pencil mark for the added node. (If the ARH350IO_V100_SET node is placed at the beginning of the flow, so that all subsequent ARH350IO_V100_MOVE node will reflect this setting).

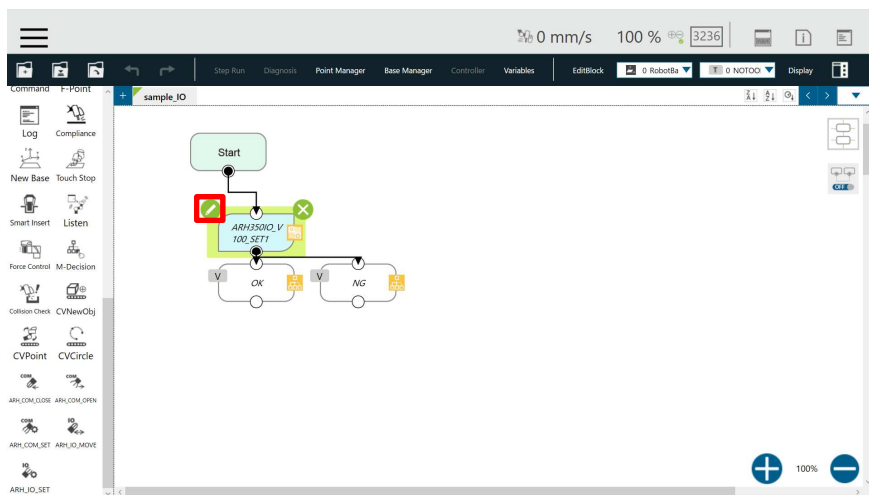

7. A separate window opens. Select SetDiGripError.

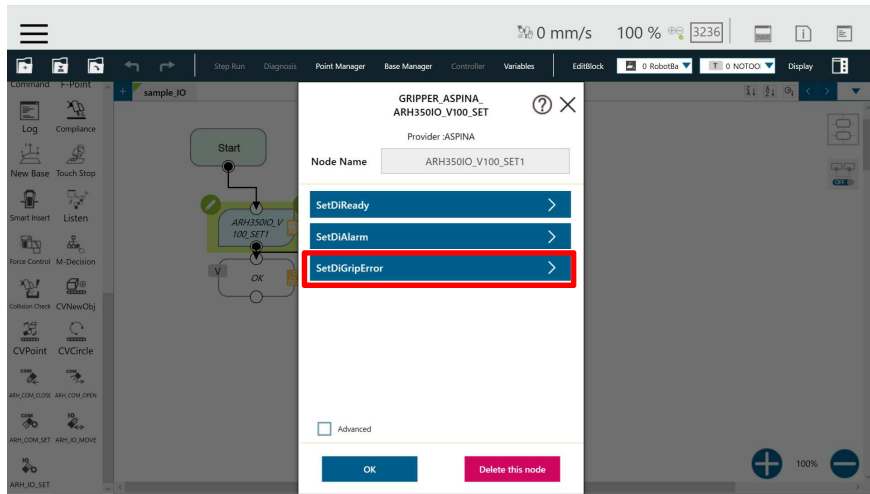

8. Select a variable. (This screen will be omitted in the following discussion.)

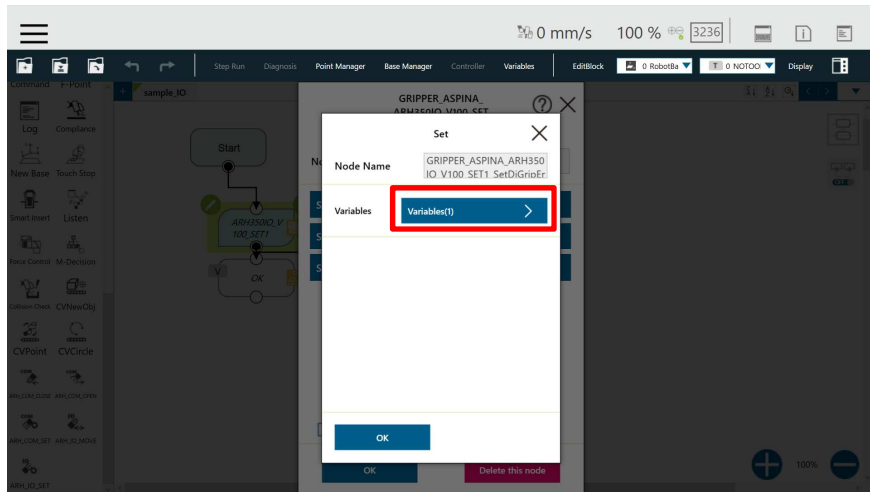

9. In the screen that opens, select the pencil mark for the variable.

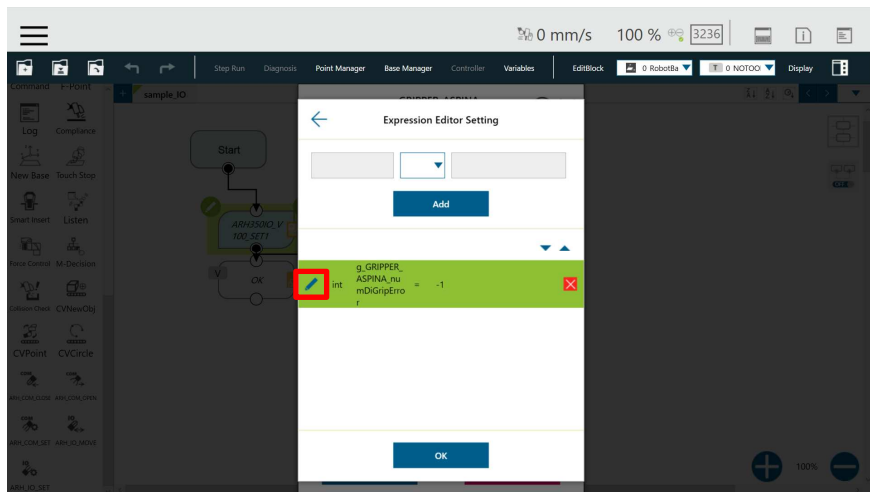

10. Delete "-1" in the text box and enter 0. Then choose OK.

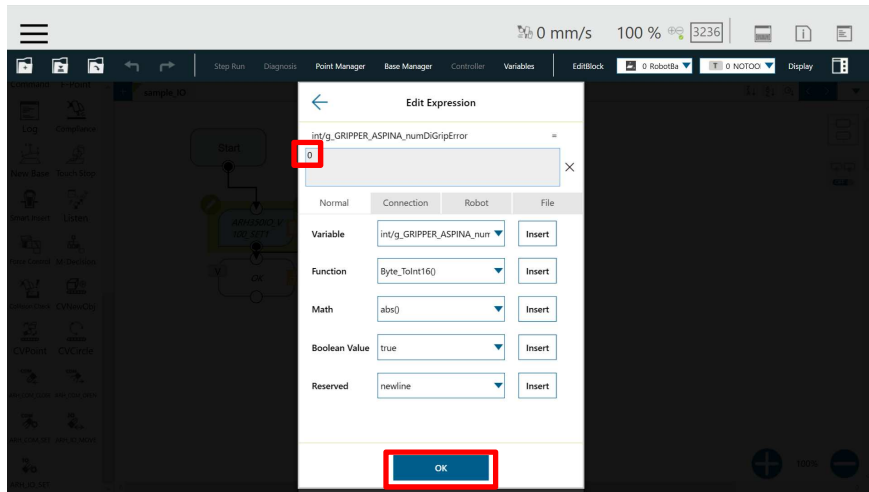

11. The right side value changes from "-1" to "0". The GripperError assigns to DI0 of the end module.

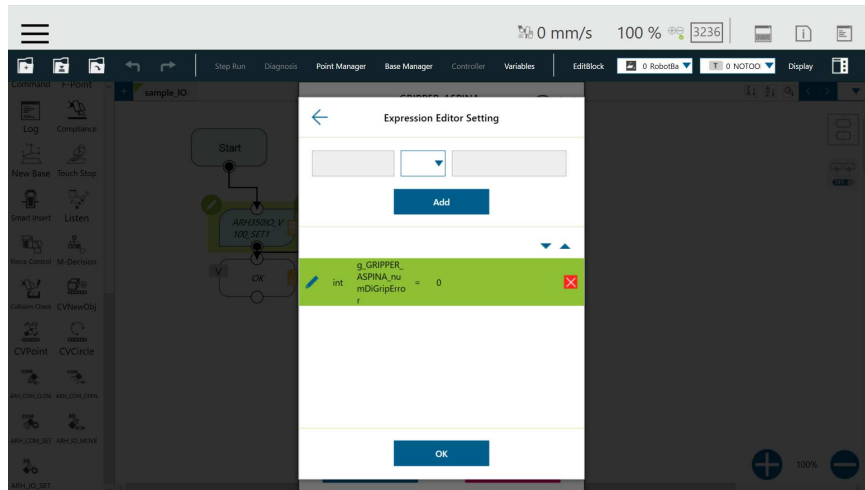

12. Repeat the previous step to numDiAlarm = 1, numDiReady = -1. The Alarm assigns to DI1 of the end module. The Ready is not assigned. .

14. Drag the node  and drop it into the flow.

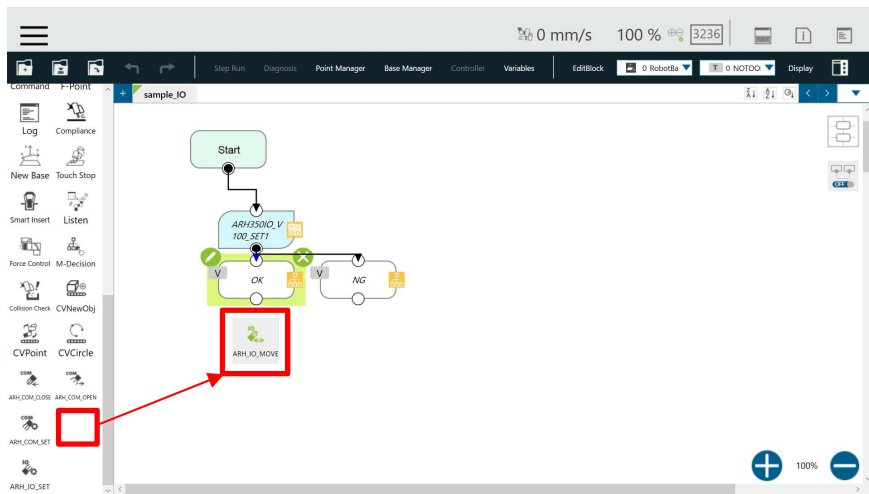

15. The node is added to the program. Select the pencil mark for the added node.

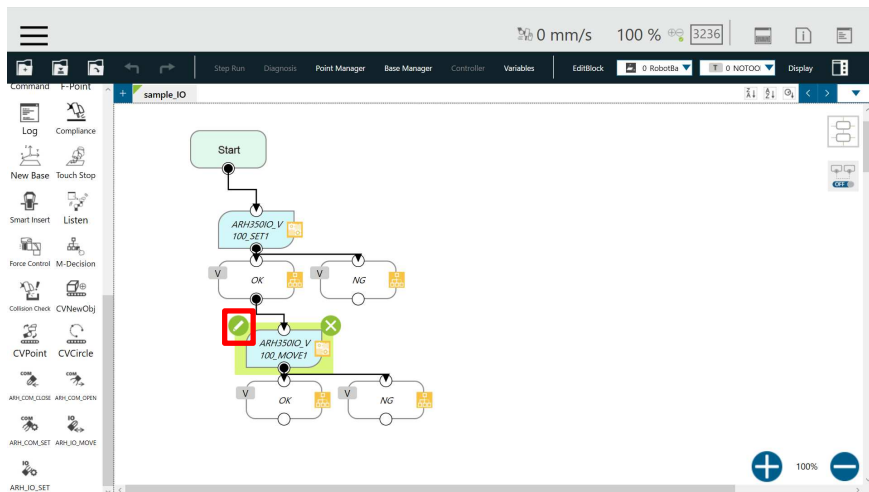

16. The setting list appears.

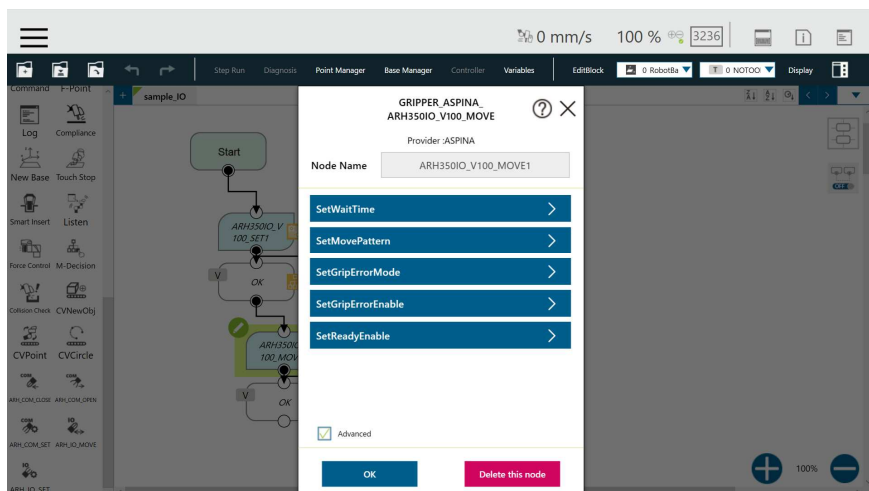

17. Set SetMovePattern = 2, Other parameters with default values.

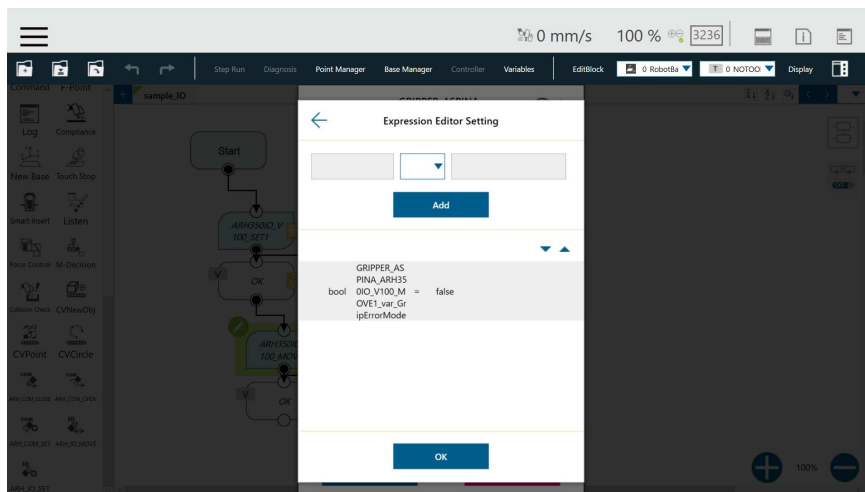
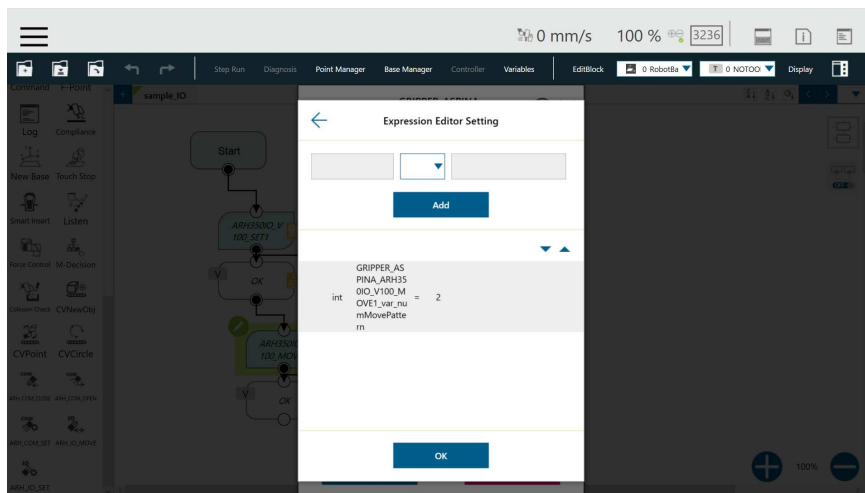
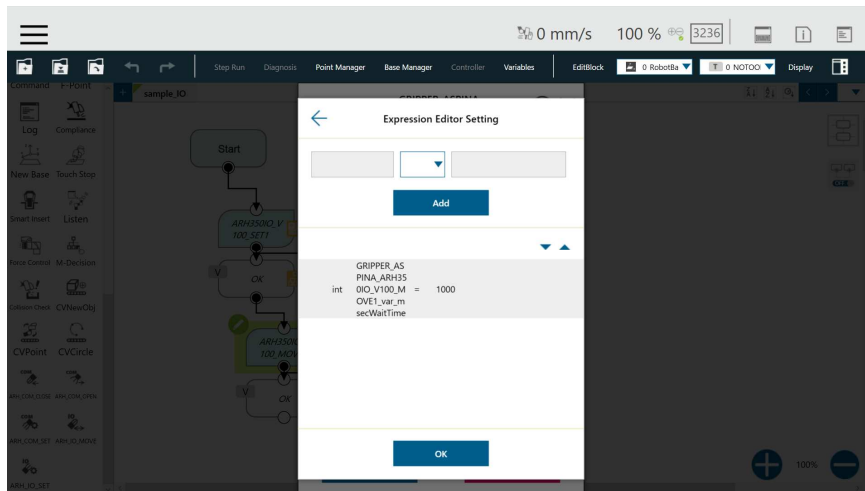

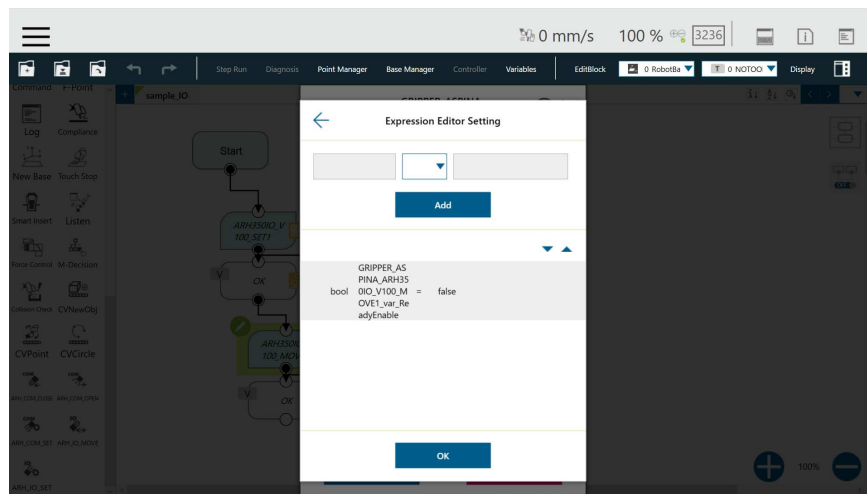
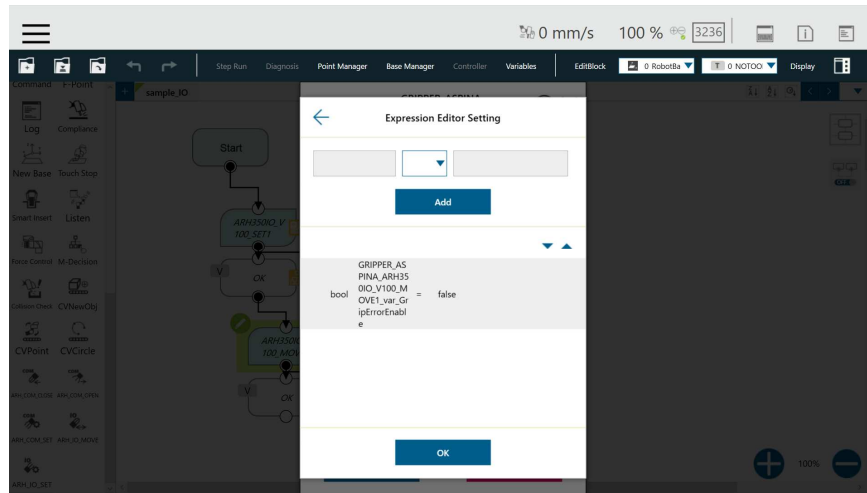

19. The setting of move pattern 2 is completed.
20. The move pattern = 1 is also added according to steps 11-16.

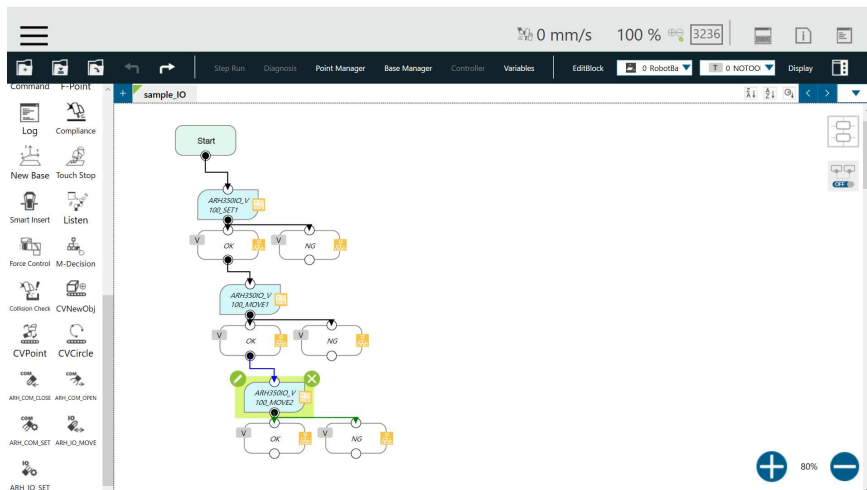

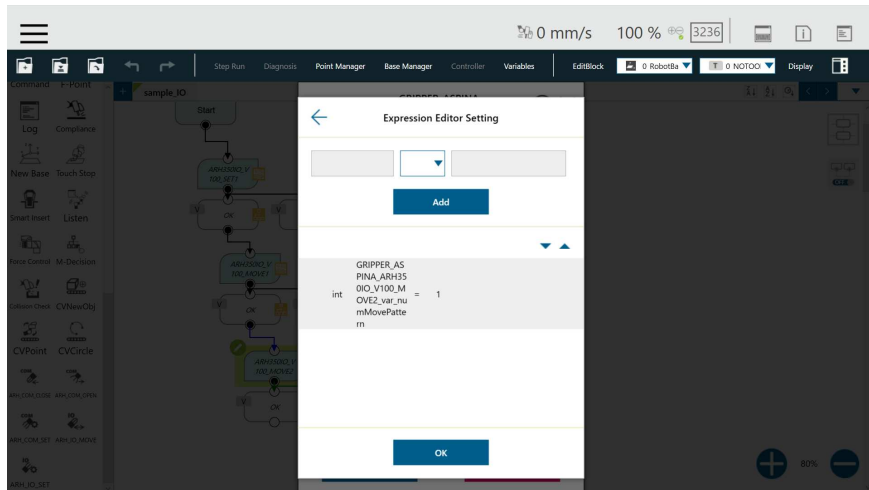

21. All settings are complete. Press the play button to run the program. Execute the operation of move pattern. The robotic gripper will close and open.

4.2. Communication control

A communication command is sent to the robotic gripper for each operation to operate the robotic gripper.

4.2.1. COM SET component

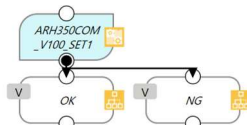
Component	Component Content	Node
 ARH_COM_SET	To set the com port and slave ID for communication control.	

The various parameters are as follows:

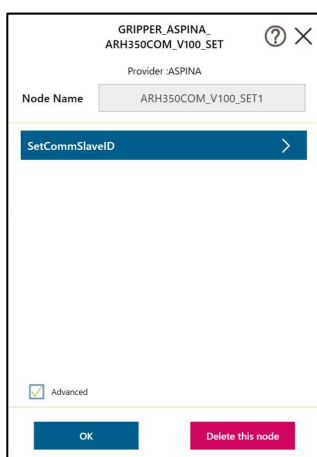



Parameter	Variable	Parameter Name	Setting range	Initial value	Contents
Basic					
SetCommSlaveID	numComport	Comport number	1 ~ 3	1	Sets the robot's com port.
	numSlaveID	Slave ID	1 ~ 31	1	Sets the slave ID of the robotic gripper.

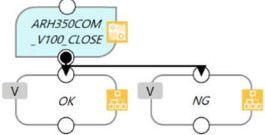

•If the settings of the com port and slave ID are wrong, communication with the robotic gripper will fail.

4.2.2. COM OPEN/CLOSE component

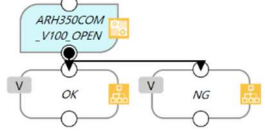
Component	Component Content	Node
 ARH_COM_CLOSE	To set parameters for closing motion or outer diameter gripping	
 ARH_COM_OPEN	To set parameters for opening motion or inner diameter gripping.	

The various parameters are as follows:.

•Basic

•Details

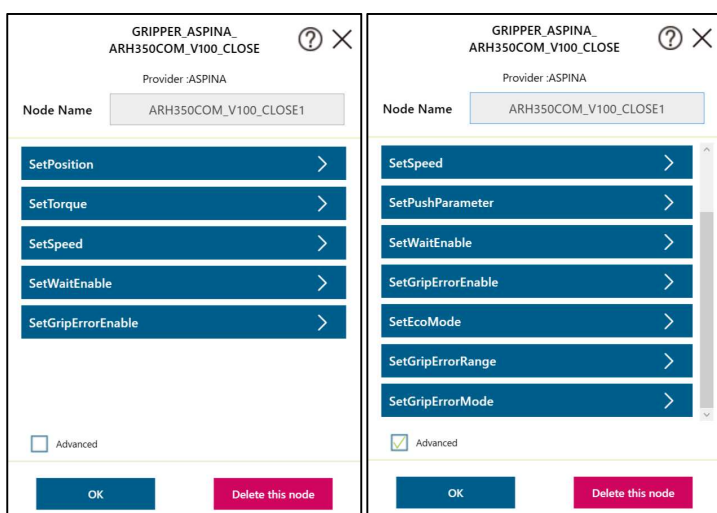

Parameter	Variable	Parameter Name	Setting range	initial value	Contents
Basic					
SetPosition	mArhPosition	target position	0 ~ 100%	OPEN: 0 CLOSE: 100	Target stop position of the robotic gripper
SetTorque	mArhTorque	Torque	15 ~ 100%	80	Torque value during the robotic gripper operation
SetSpeed	mAhSpeed	operating time	10 ~ 125%	100	Full-stroke operating speed 0.8 ~ 10 [sec]
SetWaitEnable	mIsWaitEnable	wait permission	true/false	true	Standby ON/OFF Operation Enabled/Disabled
SetGripErrorEnable	mIsGripErrorEnable	grip error permission	true/false	false	Gripper Error Enabled/Disabled

Parameter	Variable	Parameter Name	Setting range	initial value	Contents
Details					
SetPushParameter	mPushPosition	Push amount	0 ~ 100%	0	Pushing amount of the pushing operation (0 = Inactive Push)
	mPushTorque	push-in torque	0 ~ 100%	20	Torque value during pushing operation (0 = Inactive Push)
	mPushSpeed	pushing speed	0 ~ 100%	20	Operation speed during pushing operation (0 = Inactive Push)
SetEcoMode	mIsEco	eco-driving	true/false	true	Power-Saving Operation (Turn off the power supply 1 sec after gripping.) Enabled/Disabled
SetGripperErrorRange	mArhGripErrorH	Grip error output range higher limit	0 ~ 100%	OPEN: 5 CLOSE: 100	Maximum value of the GripError output range
	mArhGripErrorL	Grip error output range lower limit	0 ~ 100%	OPEN: 0 CLOSE: 95	minimum value of the GripError output range
SetGripErrorMode	mIsGripErrorMode	Grip error setting	true/false	false	Pause/Stop Processing After a grip Error Pause (true): The flow will pause after detecting a grip error. Stop (false) : The flow will stop after detecting a grip error.

4.2.2.1. Push-in operation

It allows two levels of operation within a single operation. For the push-in amount parameter, set the opening / closing width mPushPosition to set how far before the target position (mArhPosition) the push-in starts. In push operation, it is necessary to set one-step operation (mArhPosition, mArhTorque, mArhSpeed) and push operation (variable in SetPushParameter). Pushing operation can be disabled by setting mPushPosition = 0, mPushTorque = 0, and mPushSpeed = 0. The settings differ depending on the OPEN / CLOSE component.

- OPEN Component
 - Sample Configuration (The initial finger position is 100%.)
When mArhPosition = 0% and mPushPosition = 30%.

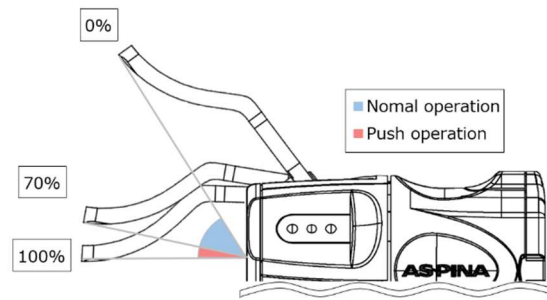

- CLOSE component

- Sample Configuration (The initial finger position is 0%.)

- When $mArhPosition = 100\%$ and $mPushPosition = 30\%$.

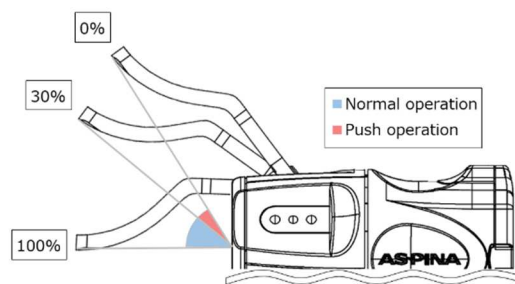

- In the OPEN component, set so that

- "target position ($mArhPosition$) < push amount ($mPushPosition$)".

- In the CLOSE component, set so that

- "target position ($mArhPosition$) > push amount ($mPushPosition$)".

4.2.2.2. Grip check

The success or failure of grasping can be determined by setting $mAhGripErrorH$ and $mAhGripErrorL$. By setting $mAhGripErrorH$ and $mAhGripErrorL$, the user can set the range to output grip errors.

- OPEN/CLOSE Component

- Configuration Example

- OPEN:

- $mAhGripErrorH = 5\%$, $mAhGripErrorL = 0\%$

- CLOSE:

- $mAhGripErrorH = 100\%$, $mAhGripErrorL = 95\%$





- Grip error output range higher limit (mArhGripErrorH) > Grip error output range lower limit (mArhGripErrorL).

4.2.3. Communication control sample program



- This program uses the com port 3. Switch according to the setting environment of the robot.

1. Please create a new project.

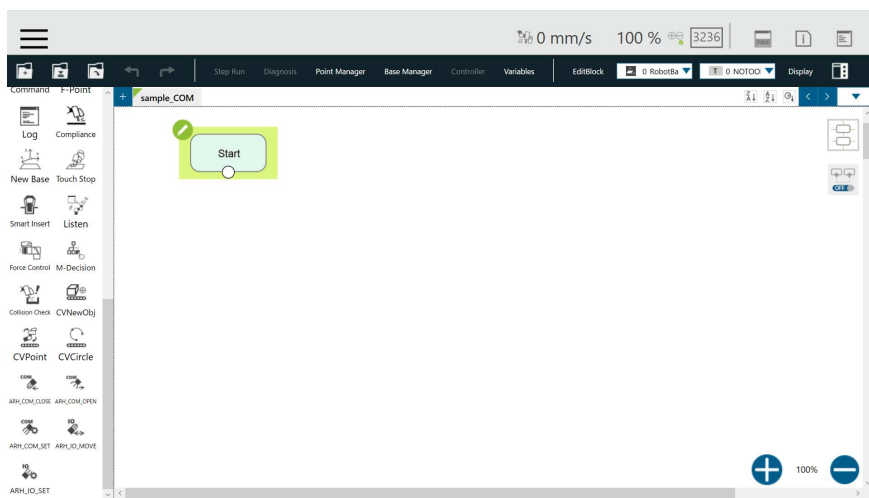

2. Drag the node  and drop it into the flow.

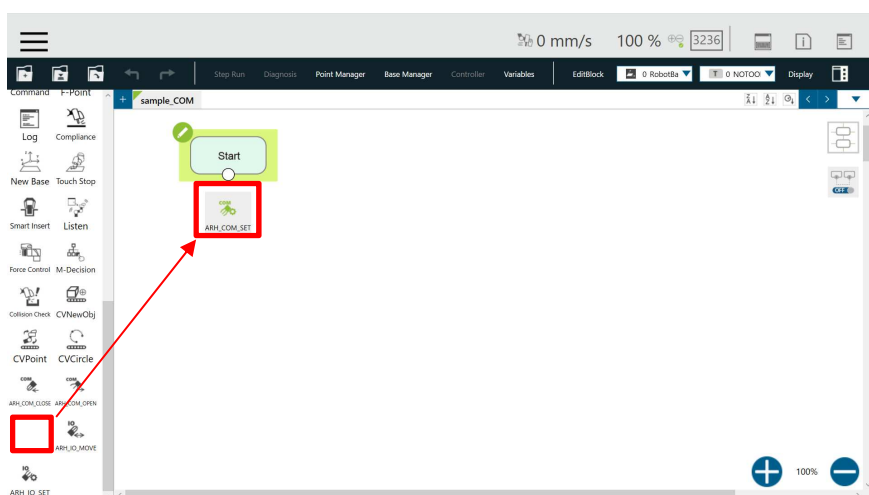

- The node is added to the program. Select the pencil mark for the added node. (The ARH350COM_V100_SET node is placed at the beginning of the flow, so that all subsequent ARH350COM_V100_OPEN/CLOSE node will reflect this setting)

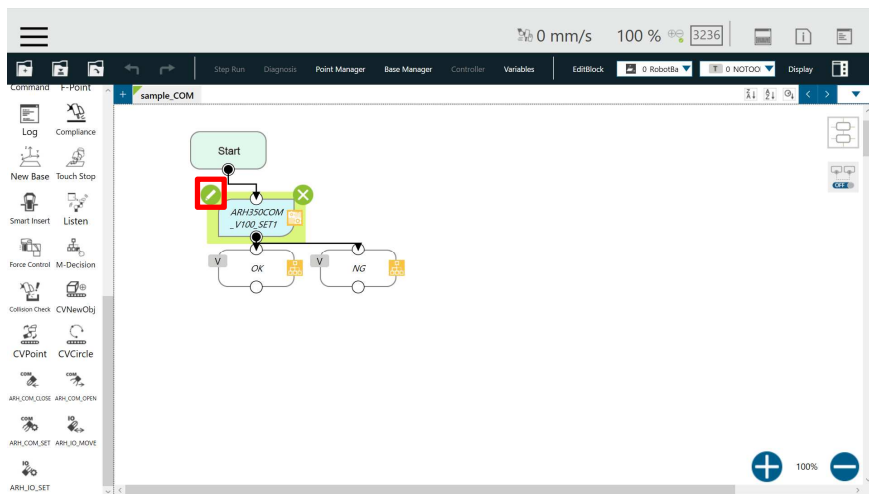

- A separate window opens. Select SetCommSlaveID.

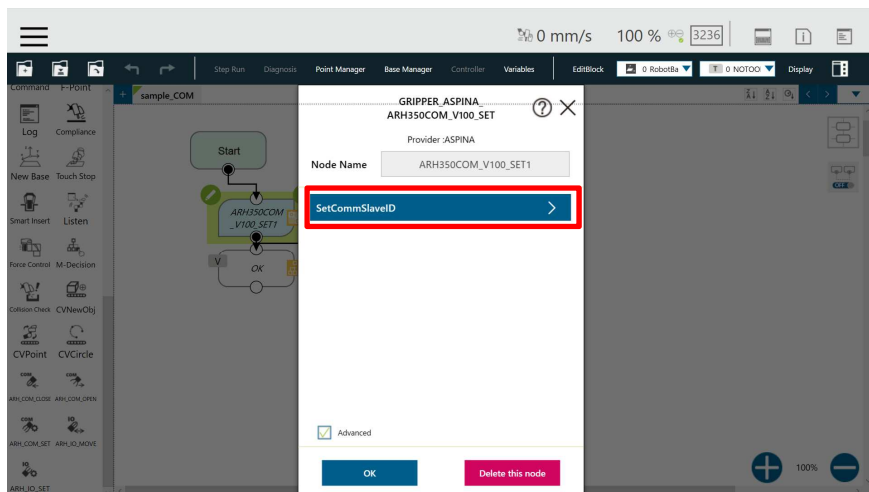

- Select a variable. (This screen will be omitted in the following discussion.)

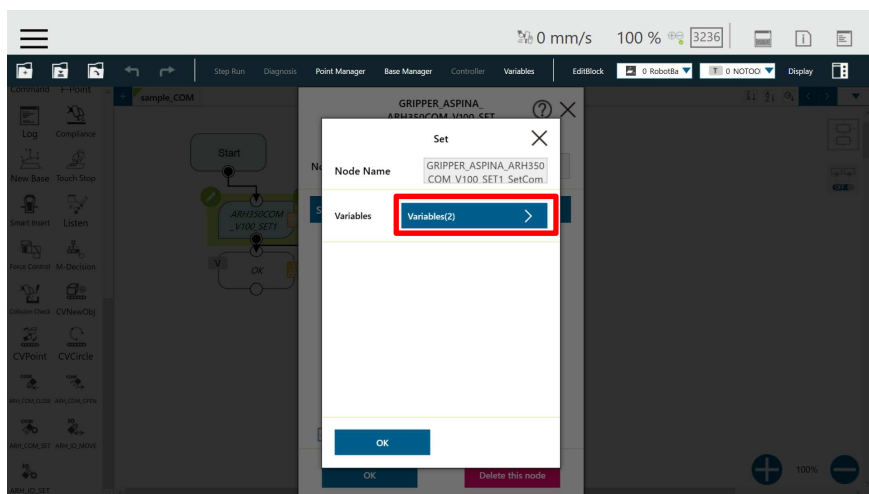

6. In the screen that opens, select the pencil mark for the variable.

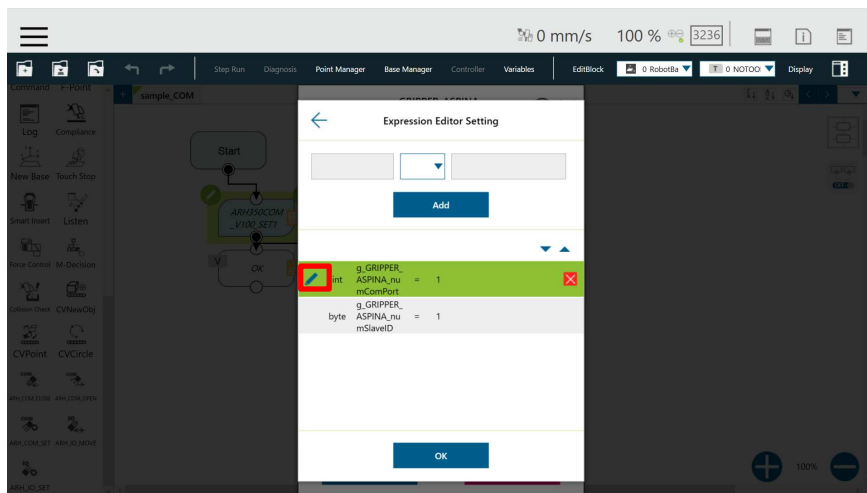

7. Delete "1" and enter "3" in the text box. Then choose OK.
(Switch the setting according to the Comport used by the robot controller.)

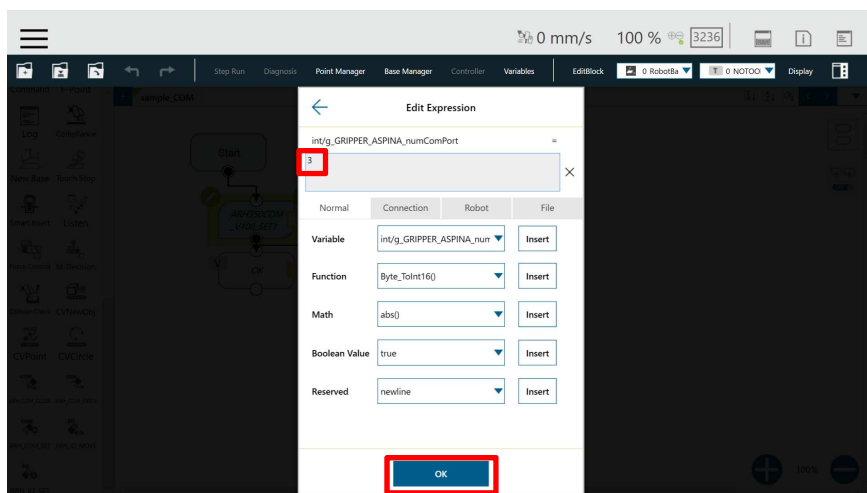

8. The right side changes from "1" to "3". This sets it to the robot com port 3.

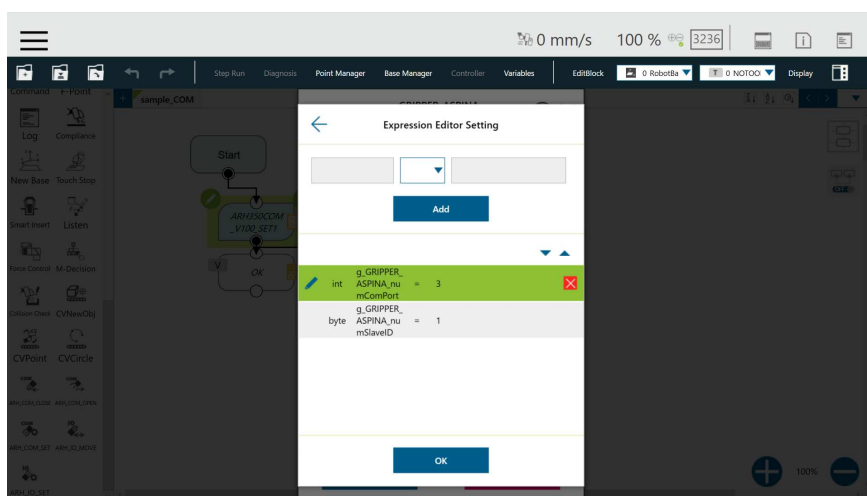

9. Repeat the previous step to set numSlaveID = 1.
10. Drag the node  and drop it into the flow.

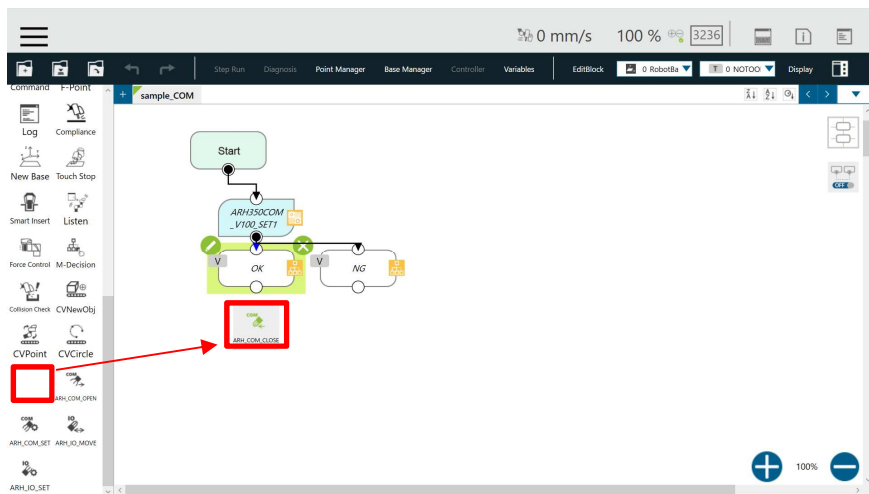

11. The node is added to the program. Select the pencil mark for the added node.

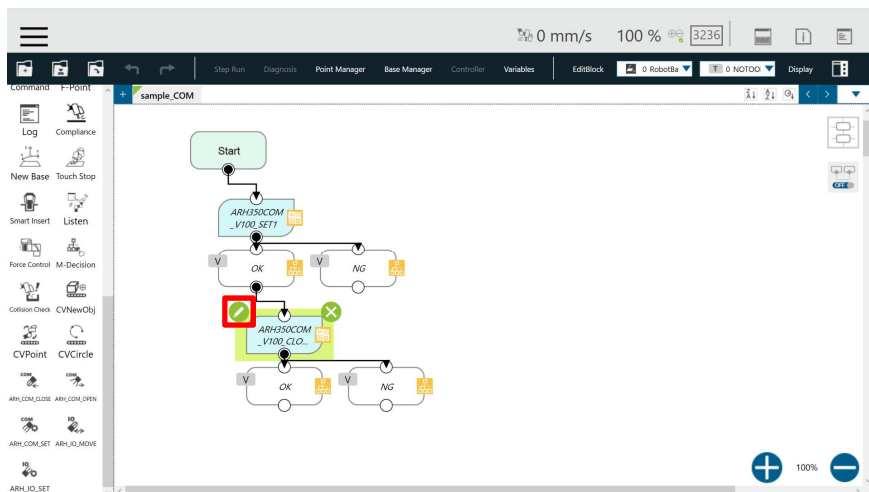

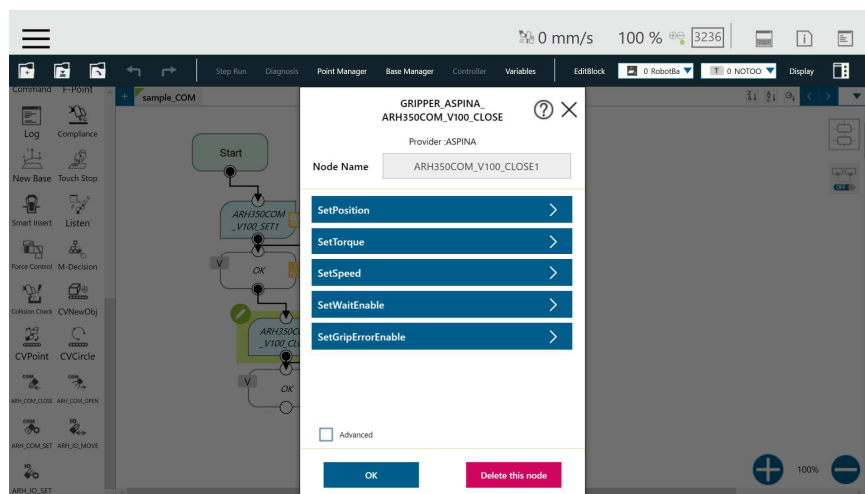

12. The setting list appears.

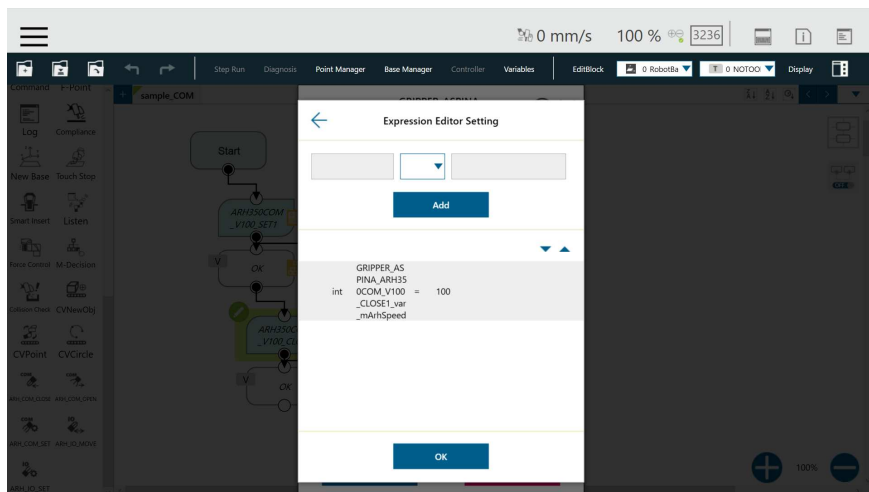
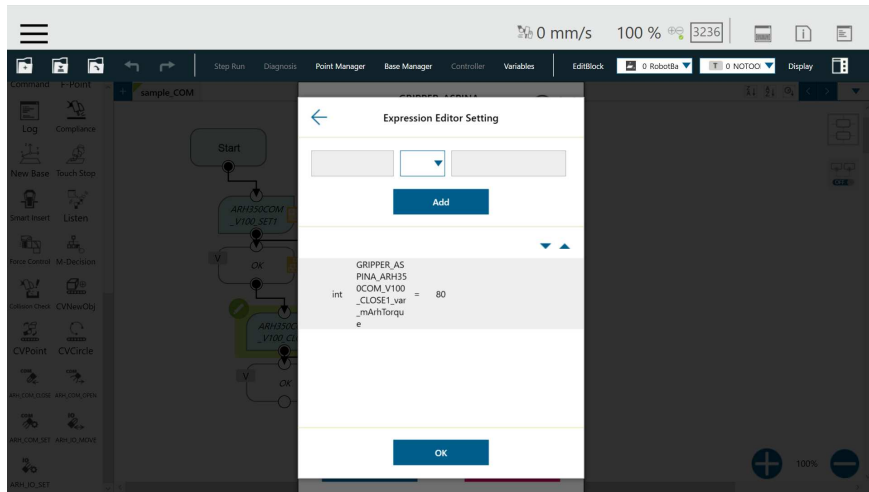
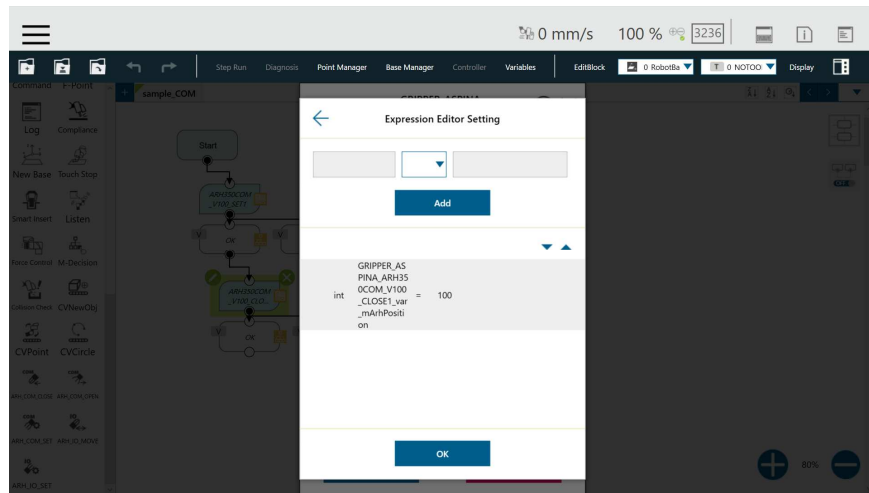

13. Set parameters with default values.

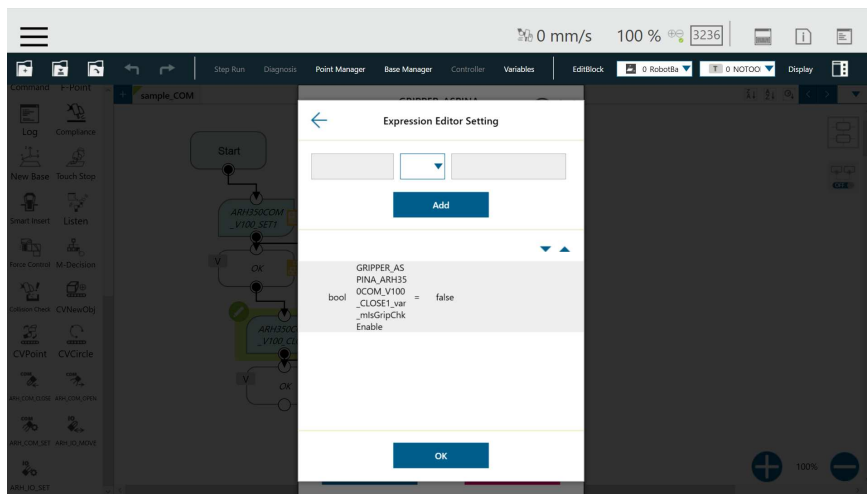
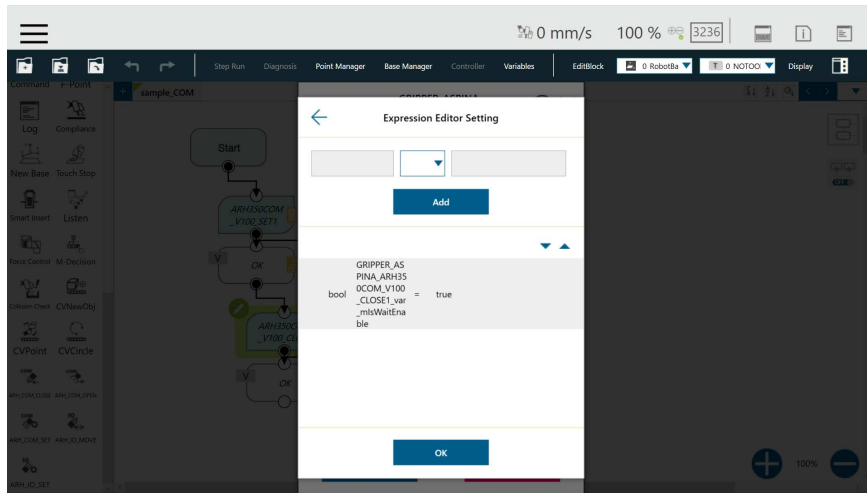



14. Place the node . Set parameters with default values.

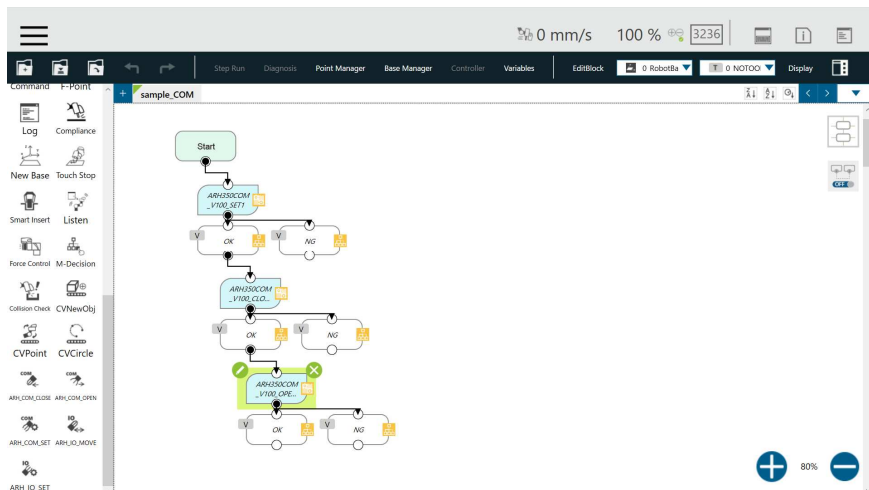

22. All settings are complete. Press the play button to run the program. Performs fully closed and fully open operation.

5. Plug-in specification

5.1. Supported Products

Supported Products

- TM5 -700/TM5M -700
- TM5 -900/TM5M -900
- TM 12/TM 12 M
- TM 14/TM 14 M

Software Version Conditions

- Version TMflow SW 1.80 or later

6. troubleshooting

6.1. Error message list

6.1.1. ARH350IO Component Error

The errors in the IO component are:

error code	Contents	Countermeasures
E000	Alarm detected before operation.	Check the alarm.
E001	Alarm detected after operation.	Check the alarm.
E002	Alarm detected while waiting for Ready signal.	Check the alarm.
E003	Ready signal wait time has exceeded 12 seconds.	Check the fingers weight or alarm.
E004	GripError detected.	Check if there is a workpiece.
E005	Invalid numMovePattern setting.	Set numMovePattern within a range of 1 ~ 4.
E006	Invalid msecWaitTime setting.	Set msecWaitTime within a the range of 0 ~ 10000 msec.
E007	Invalid numValReady setting.	Set numValReady within a range of -1 ~ 1
E008	Invalid numValAlarm setting.	Set numValAlarm within a range of -1 ~ 1
E009	Invalid numValGripError setting.	Set numValGripError within a range of -1 ~ 1
E010	Ready, Alarm, GripError setting conflict.	Ready, Alarm, and GripError must be assigned -1, 0, 1 respectively.

6.1.2. ARH350COM component error

The errors in the COM component are:

Error code	Contents	Countermeasures
E100	Communication failed.	Check the Comport, SlaveID, and wiring.
E101	Alarm detected before operation.	Check the alarm.
E102	Alarm detected while waiting for Ready signal.	Check the alarm.
E103	Alarm detected after operation	Check the alarm.
E104	Ready signal wait time has exceeded 12 seconds.	Check the fingers weight or alarm.
E105	Invalid mArhPosition setting.	Set the mArhPosition within a range of 0 ~ 100%.
E106	Invalid mArhTorque setting	The mArhTorque setting should be in the 15 ~ 100% range.
E107	Invalid mArhSpeed setting.	Set the mArhSpeed within a range of 10 ~ 125%.
E108	Invalid mPushPosition setting.	Set the mPushPosition within a range of 0 ~ 100%.
E109	mArhPosition must set higher than or equal to mPushPosition value.	The mArhPosition must set higher than or equal to the mPushPosition value.
E110	Invalid mPushTorque setting.	Set mPushTorque within the 15 ~ 100% range.

E111	Invalid mPushSpeed setting.	Set the mPushSpeed within the 0 ~ 100% range.
E112	mArhGripErrorH must be set higher than the value of mArhGripErrorL.	Set mArhGripErrorH to higher than the value of mArhGripErrorL.
E113	Invalid mArhGripErrorH setting.	Set mArhGripErrorH in the range of 0 ~ 100%.
E114	Invalid mArhGripErrorL setting.	Set mArhGripErrorL in the range of 0 ~ 100%.
E115	Invalid mArhPosition setting.	The mArhPosition is set within 0 ~ 100%.
E116	Invalid COM number.	COM must be set within the range of 1 ~ 3.
E117	Invalid SlaveID number.	SlaveID must be between 1 ~ 31.
E118	Communication timed out and failed. Check the wiring and setting.	Check the Comport, SlaveID and wiring.
E119	mPushPosition value must set higher than or equal to mArhPosition value.	The mPushPosition value must set higher than or equal to the mArhPosition value.
E120	The value of mArhPosition + mPushPosition cannot exceed 100%.	Set the value of mArhPosition + mPushPosition to within 100%.

7. Release Notes

7.1. ASPINA _ ARH 350 version 00.01.00 beta

- initial public version

7.2. ASPINA _ ARH 350 version 00.02.00 beta

Compatible with TMflow 1.80 and later.

- GRIPPER_ASPINA_ARH350IO_V002_SET

Add the icon name.

Add the manual.

- GRIPPER_ASPINA_ARH350IO_V002_MOVE

Add the icon name.

Add the manual.

Change initial value : SetReadyEnable initial value = true → false

- GRIPPER_ASPINA_ARH350COM_V002_SET

Add the icon name.

Add the manual.

•GRIPPER_ASPINA_ARH350COM_V002_CLOSE

Add the icon name.

Add the manual.

- GRIPPER_ASPINA_ARH350COM_V002_OPEN

Add the icon name.

Add the manual.

Improve initial value :

SetGripperErrorRange mArhGripErrorH = 100 → 5

SetGripperErrorRange mArhGripErrorL = 95 → 0

7.3. ASPINA _ ARH 350 version 00.03.00 beta

Compatible with TMflow 1.80 and later.

- GRIPPER_ASPINA_ARH350IO_V003_MOVE

Enable parameter : SetReadyEnable

7.4. ASPINA _ ARH 350 version 01.00.00 release

Compatible with TMflow 1.80 and later.

- GRIPPER_ASPINA_ARH350IO_V100_SET

Replace the manual(xps)

- GRIPPER_ASPINA_ARH350IO_V100_MOVE

Replace the manual(xps)

At Display node E007, 8, 9, improve variable name Val → Di.

- GRIPPER_ASPINA_ARH350COM_V100_SET

Replace the manual(xps)

- GRIPPER_ASPINA_ARH350COM_V100_CLOSE

Replace the manual(xps)

Improve variable mArhPositon → mArhPosition

- GRIPPER_ASPINA_ARH350COM_V100_OPEN

Replace the manual(xps)

Improve variable mArhPositon → mArhPosition

8. revision history

Date	edition	Contents
2021/02/02	0.00	Initial Creation
2021/03/11	0.01	<ul style="list-style-type: none"> 2. Change all figures. Add the position figure of 4 patterns. 2.2.1. Add converter setting. 3.2. Revise the sentence in step 2 4.1.2. Revise SetReadyEnable initial value. <ul style="list-style-type: none"> Add the sentence about Pause/Stop description to SetGripErrorMode 4.1.3. Add the sentence and table about move pattern to step 1. <ul style="list-style-type: none"> Change step contents 4.2.2. Add the sentence about Pause/Stop description to SetGripErrorMode 4.2.2.1. Revise from Japanese to English at figures 4.2.3. Change step contents 5.1. Change the TM flow vesion 6.1.1. Revise the error code
2021/04/05	1.00	<ul style="list-style-type: none"> 1. Change all figures to TMflow 1.80 version 2. Add IO, COM operation information. 4. Change related figures to TMflow 1.80 version 4.1 Add Start node uncheck process 7. Add release notes